

Drive^{IT} Low Voltage AC Drives

User's Manual

Pulse Encoder Interface Module OTAC-01

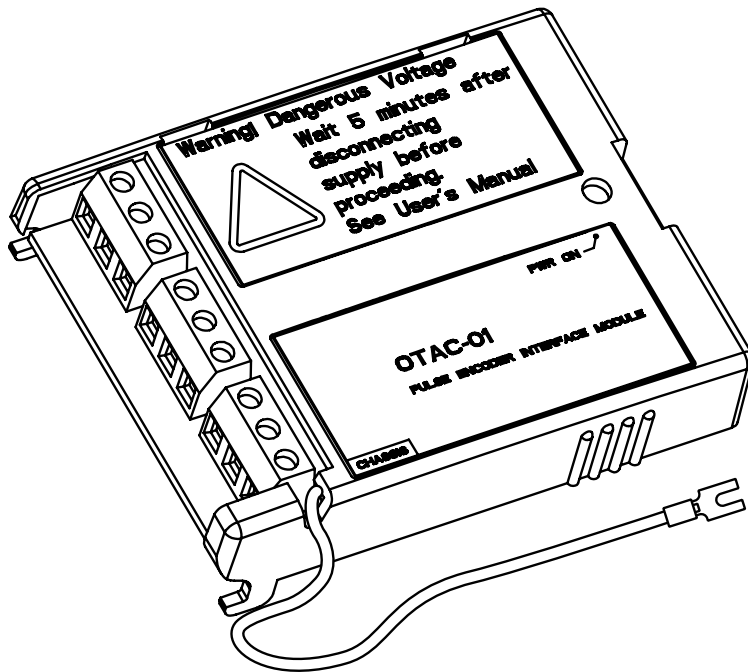

Safety



WARNING! All electrical installation and maintenance work on the drive should be carried out by qualified electricians only.



WARNING! The drive and adjoining equipment must be properly grounded.



WARNING! Do not attempt any work on a powered drive. After switching off the mains, always allow the intermediate circuit capacitors 5 minutes to discharge before working on the drive, the motor or the motor cable. It is good practice to check (with a voltage indicating instrument) that the drive is in fact discharged before beginning work.



WARNING! The motor cable terminals of the drive are at a dangerously high voltage when mains power is applied, regardless of motor operation.



WARNING! There can be dangerous voltages inside the drive from external control circuits even when the drive mains power is shut off. Exercise appropriate care when working on the unit. Neglecting these instructions can cause physical injury or death.

Use of Warnings and Notes

There are two types of safety instructions throughout this manual:

- Notes draw attention to a particular condition or fact, or give information on a subject.
- Warnings caution you about conditions which can result in serious injury or death and/or damage to the equipment. They also tell you how to avoid the danger. The warning symbols are used as follows:



Dangerous voltage warning warns of high voltage which can cause physical injury and/or damage to the equipment.

Table of Contents

Safety	2
Use of Warnings and Notes	2
Table of Contents	3
Installation	4
Preparing for Installation	4
Installing the Module	5
Start-Up	13
Configuration	13
Diagnostics	16
Diagnostic LED	16
Fault/Warning	16
Technical Data	18

Installation

Preparing for Installation

The OTAC-01 Module

The OTAC-01 Pulse Encoder Interface module is an interface for connecting a digital pulse encoder to an ACS550 drive. A pulse encoder should be used if accurate speed or position (angle) feedback from the motor shaft is required.

Module Layout

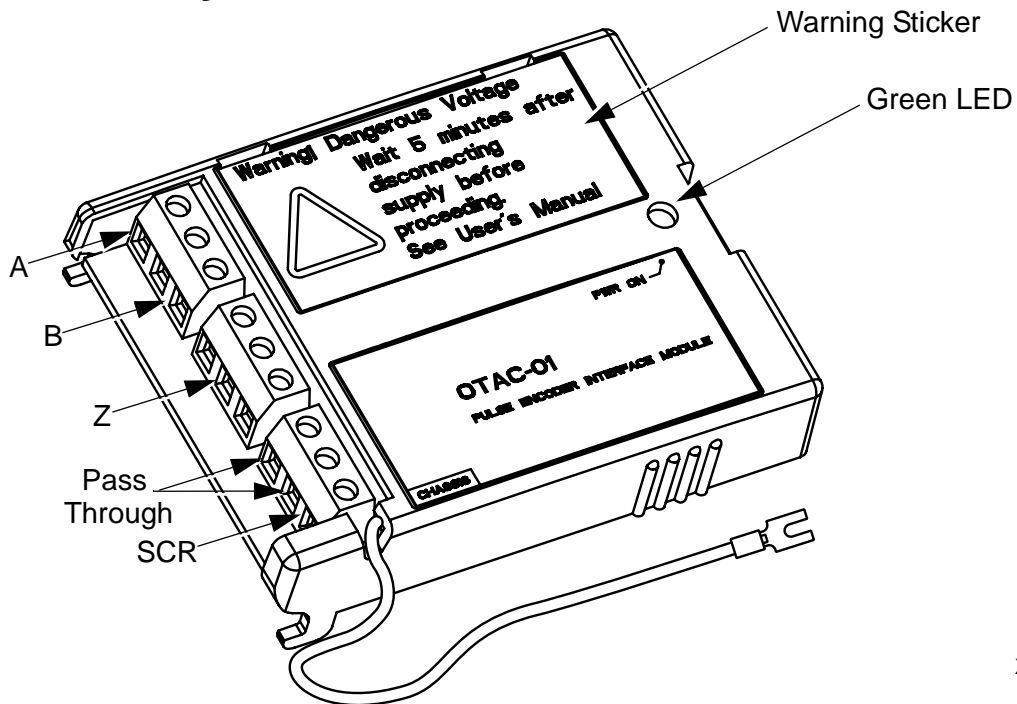

X0061

Compatibility

The OTAC-01 module is compatible with all ACS550 drives. To confirm compatibility with a particular pulse encoder, compare the pulse encoders requirements to the "Specifications" on page 19.

Installing the Module

Delivery Check

The OTAC-01 module package contains:

- OTAC-01 module
- Warning stickers in several languages
- This manual

Mounting



WARNING! Follow the safety instructions given in this guide and in the *ACS550 User's Manual*.

To mount the OTAC-01 module:

1. If not already off, remove mains power from the drive.
2. Remove the drive cover. (See instructions in the drive User's Manual.)
3. Insert the OTAC-01 module's plastic hooks into the front of the drive at SLOT 1.
4. Carefully fit the connector at the other end of the module into the drive connector.
5. Press until the retaining clip locks the module into position.

NOTE! Signal and power connections to the drive are automatically made through a 6-pin connector.

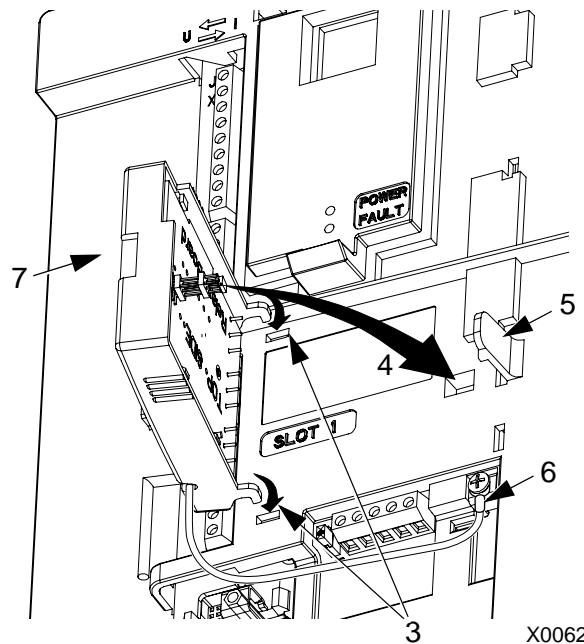

6. Connect the ground lead to the chassis screw terminal on the drive.

X0062

NOTE! Correct installation of the ground lead is essential for fulfilling the EMC requirements and for proper operation of the module.

7. Non-English speaking locations: Add a warning sticker in the appropriate language over the existing warning on the top of the module.

Wiring – General

The pulse encoder should be connected to the OTAC-01 module with cables as specified below.

Cable construction	4 × (2+1) Twisted pair cable with individual and overall shields.	
Conductor cross-sectional area	0.5 to 1.5 mm ²	20 to 16 AWG

Terminal Designations

Use the following table for reference when wiring terminals.

Identification				Description
OTAC	Encoder			
A	1	A	A+	<ul style="list-style-type: none"> Max. signal frequency: 200 kHz Signal levels: Logic "1": 7.5 to 26 V Logic "0": < 0.8 V Input channels isolated from the logic, and ground When the drive runs in the <i>Forward</i> direction, channel A should lead channel B by 90° (electrical) Channel Z: One pulse per revolution (used in positioning applications only)
\bar{A}	$\bar{1}$	\bar{A}	A-	
B	2	B	B+	
\bar{B}	$\bar{2}$	\bar{B}	B-	
Z	3	Z	Z+	
\bar{Z}	$\bar{3}$	\bar{Z}	Z-	
(PWR)	V _{CC} / PWR			OTAC-01 does not provide a power supply. These terminals are used for daisy chaining between the power supply and the encoder.
(GND)	0 V / GND			
SCR	SCR / Shield			Used for grounding of the encoder cable shields. Connected internally to the drive frame.

Wiring – The Encoder Power

The OTAC-01 module does not supply power for the encoder. An external power supply (as diagrammed below) is recommended. The drive's 24 VDC supply from terminals X1:10 and X1:11 can be used if the total draw on the supply does not exceed 250 mA. Use the following table to determine if the drive's supply can be used.

Loads Using the Drive's 24 VDC Supply		mA
Number of digital inputs used (DI1...DI6)		x 15 mA each =
Encoder current requirement =		
Total requirements for any other user connection(s) to drive's 24 VDC =		
Total (must be less than 250 mA) =		

1. Connect as follows:

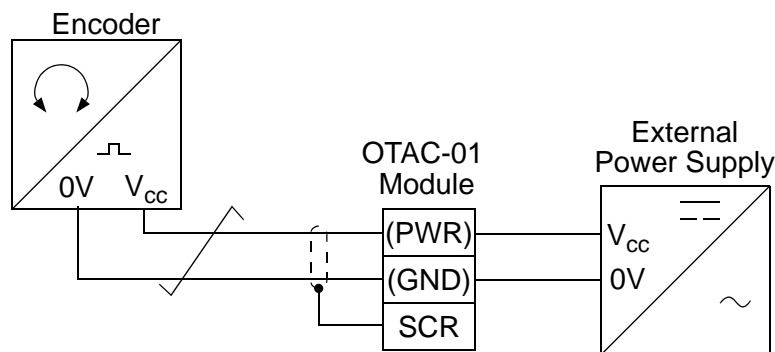

Wiring – The Encoder

1. Determine the encoder wiring configuration:
 - Refer to “Phasing” on page 8 to determine if the encoder has normal pulse order – encoder channel A/1 pulse leads channel B/2 pulse.
 - Refer to “Encoder Output Types” on page 9 to determine the encoder's output type.
 - For push-pull types, refer to the manufacturer's recommendation for connection – either *single-ended* or *differential* can be used.
2. Refer to “Wiring Diagrams” on page 10, select the appropriate diagram, and wire the encoder.

Note: Normally, ground the cable shield only at the drive end. However, if the encoder is isolated from the motor, and from ground, then connect the cable shields to both the OTAC module and the encoder housing.

Note: Do not route the encoder cables parallel to power (e.g. motor) cables.

3. Verify correct encoder phasing. See options below.

Phasing

When the encoder is connected correctly, running the drive in the *Forward* (positive speed reference) direction should produce a positive encoder speed feedback.

Option A: Oscilloscope Test. On incremental encoders, the two output channels, usually marked A and B or 1 and 2, are 90° (electrical) apart from each other. When rotated clockwise, most encoders – but not all – have channel A/1 leading channel B/2 as illustrated below. Determine the leading channel by referring to the encoder documentation or by measuring with an oscilloscope.

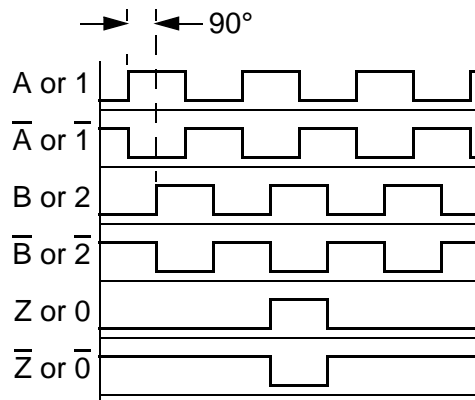

Diagrams show normal phasing: Pulse A/1 leads (i.e. rises earlier than) pulse B/2.

Connect the zero reference output channel (usually marked 0, N or Z) only if parameter 5010 Z PLS ENABLE = 1 (ENABLE).

The encoder output channel that leads when the drive runs *Forward* should be connected to OTAC terminal A. The output channel that trails should be connected to OTAC terminal B.

Option B: Functional Test. For this test:

- Temporarily, switch the drive to scalar mode (parameter 9904 = 3), if not already there.

- Run the drive in the forward direction.
- Verify that parameter 0147 MECH REVS is increasing in the positive direction.
- If not, switch the A/\bar{A} (or $1/\bar{1}$) connections.

Encoder Output Types

The following diagrams identify the typical encoder output types.

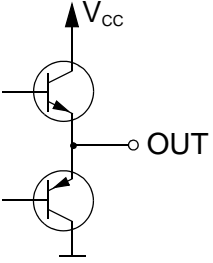
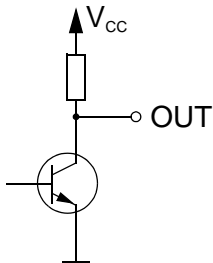
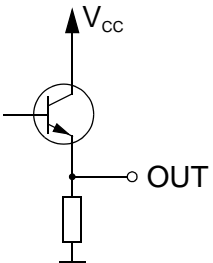
Push-pull	Open collector (Sinking)	Open emitter (Sourcing)
		
V_{CC} = Encoder input power supply voltage		

Wiring Diagrams

Push-Pull Type Encoder Output

Diagram assumes normal pulse order in Forward rotation: Pulse A/1 leads as diagrammed below

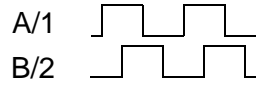

For encoders with pulse 2 leading, change diagram for these connections:

- Encoder A/1 and B/2 should be wired to OTAC terminals B and A respectively.
- Encoder $\bar{A}/\bar{1}$ and $\bar{B}/\bar{2}$ (if present) should be wired to OTAC terminals \bar{B} and \bar{A} respectively.

Differential connection

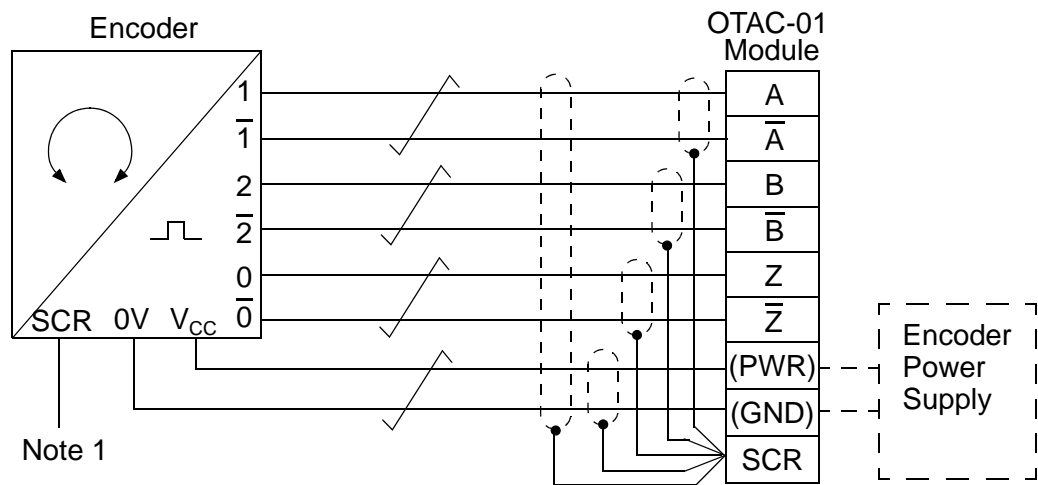

Single-ended connection

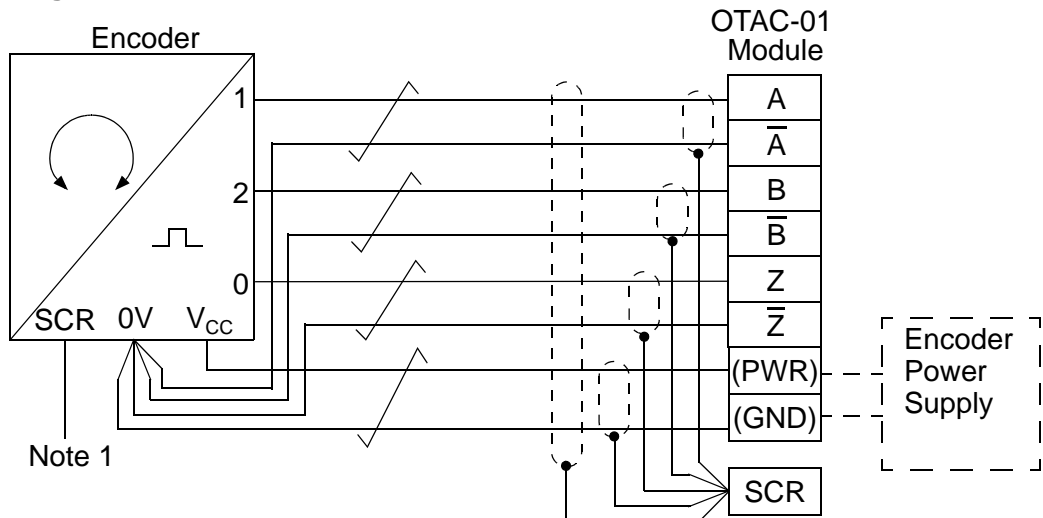

Note 1: Connect the cable shield at the encoder housing, if, and only if, the encoder is isolated from the motor, and from ground.

Open Collector (Sinking) Encoder Output

Diagram assumes normal pulse order in Forward rotation: Pulse 1 leads as diagrammed below

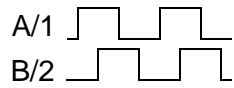

For encoders with pulse B/2 leading, change diagram for these connections:
Encoder A/1 and B/2 should be wired to OTAC terminals B and A respectively.

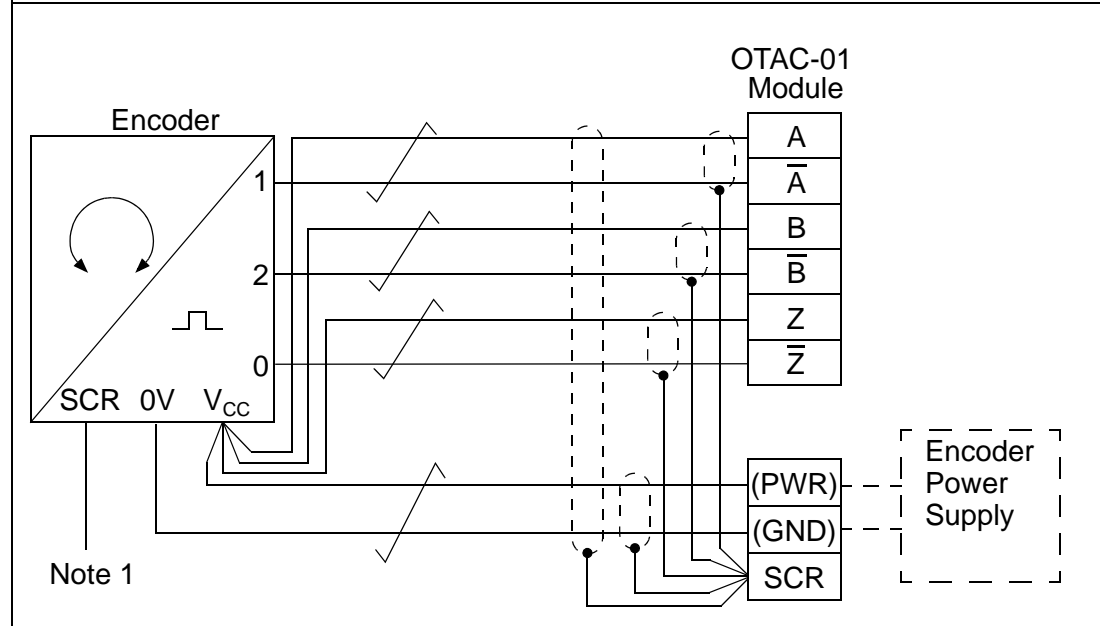

Note 1: Connect the cable shield at the encoder housing, if, and only if, the encoder is isolated from the motor, and from ground.

Open Emitter (Sourcing) Encoder Output

Diagram assumes normal pulse order in Forward rotation: Pulse 1 leads as diagramed below

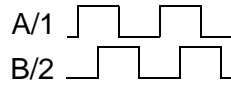

For encoders with pulse B/2 leading, change diagram for these connections:
Encoder A/1 and B/2 should be wired to OTAC terminals B and A respectively.

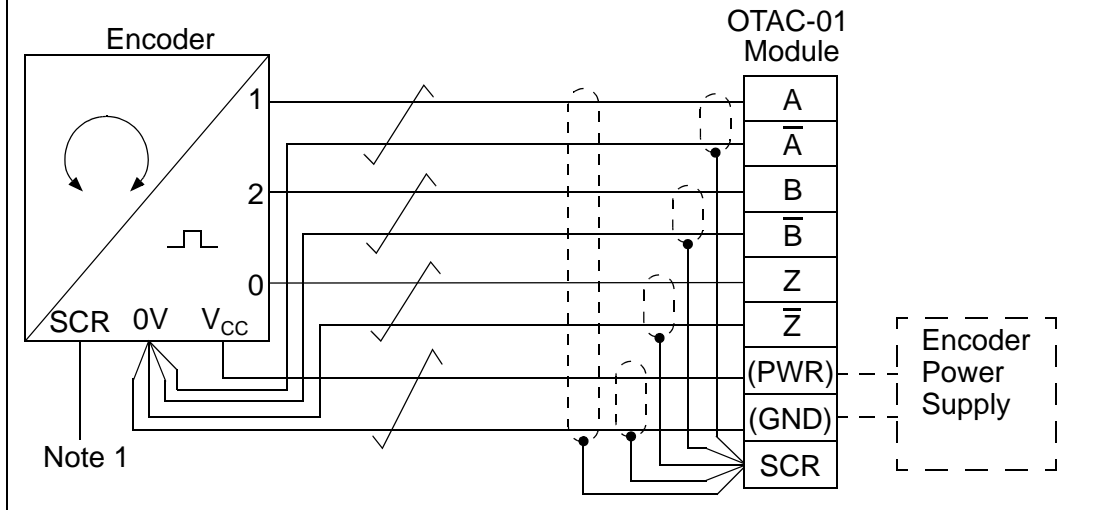

Note 1: Connect the cable shield at the encoder housing, if, and only if, the encoder is isolated from the motor, and from ground.

Replace Drive Cover

1. Refer to the drive's User's manual and replace the drive's cover.

Apply Power

1. Turn on the mains power to the drive.

Note! When power is applied to the drive, the LED on the OTAC module should light.

2. Continue with the next section, Start-Up.

Start-Up

Configuration

To configure the operation of the OTAC-01 module:

1. Power up the drive.
2. Use the control panel on the drive and set the parameters described below.

Operating Data

The following parameters provide feedback from the encoder. The drive sets the parameter values based on measurements or calculations. You cannot set these values directly, but you can use Group 50 parameters to control mechanical angle and revolution data.

Group 01: Operating Data				
Code	Description	Range	Resolution	Default
0146	MECH ANGLE Defines the motor shaft's angular position to about 0.01° (32,768 divisions for 360°). The position is defined as 0 at power up. During operation the zero position can be set by: <ul style="list-style-type: none"> • A Z-pulse input, if parameter 5010 Z PLS ENABLE = 1 (ENABLE) • Parameter 5011 POSITION RESET, if parameter 5010 Z PLS ENABLE = 2 (DISABLE) • Any status change of parameter 5002 ENCODER ENABLE 	0...32767	1 (≅ 0.01°)	0
0147	MECH REVS A signed integer that counts full revolutions of the motor shaft. The value: <ul style="list-style-type: none"> • Increments when parameter 0146 MECH ANGLE changes from 32767 to 0 • Decrements when parameter 0146 MECH ANGLE changes from 0 to 32767 	-32767...32767	1	0
0148	Z PLS DETECTED When a Z-pulse defines the zero position, the shaft must pass through the zero position to trigger a Z-pulse. Until then, the shaft position is unknown (the drive uses the shaft position at power up as zero). This parameter signals when parameter 0146 MECH ANGLE is valid. This parameter starts at zero on power-up and changes to 1 only if: <ul style="list-style-type: none"> • Parameter 5010 Z PLS ENABLE = ENABLE and • An encoder Z-pulse has been detected. 	0, 1	1	0

Encoder

This group defines the setup for encoder use:

- Set the number of encoder pulses per shaft revolution.
- Enable the encoder operation.
- Defines how mechanical angle and revolution data is reset.

Note! a check under the heading “S” indicates that the parameter can only be modified when the drive is stopped.

Group 50: Encoder					
Code	Description	Range	Resolution	Default	S
5001	PULSE NR Sets the number of pulses provided by an optional encoder for each full motor shaft revolution.	0...16384 ppr	1	1024	✓
5002	ENCODER ENABLE Enables/disables optional external encoder. 0 = DISABLE – Drive uses speed feedback derived from the internal motor model (applies for any setting of parameter 9904 MOTOR CTRL MODE). 1 = ENABLE – Drive uses feedback from an optional encoder. This function requires the Pulse Encoder Interface Module (OTAC-01) and an encoder. Operation depends on the setting of parameter 9904 MOTOR CTRL MODE: • 9904 = 1 (VECTOR: SPEED), the encoder provides improved speed feedback and improved low speed torque accuracy. • 9904 = 2 (VECTOR: TORQ), the encoder provides improved speed feedback and improved low speed torque accuracy. • 9904 = 3 (SCALAR: SPEED), the encoder provides speed feedback. (This is not closed loop speed regulation. However, using parameter 2608 SLIP COMP RATIO and an encoder improves steady state speed accuracy.)	0, 1	1	0	✓
5003	ENCODER FAULT Defines the drive response if the encoder signal is lost. 1 = FAULT – A fault is generated, and the motor coasts to a stop. 2 = WARNING – An alarm is generated and the ACS550 operates as is if parameter 5002 ENCODER ENABLE = 0 (DISABLE), that is, speed feedback is derived from the internal motor model.	1, 2	1	1	✓
5010	Z PLS ENABLE Enables/disables the use of an encoder's Z-pulse to define the motor shaft's zero position. When enabled, a Z-pulse input resets parameter 0146 MECH ANGLE to zero to define the shaft's zero position. This function requires an encoder that provides Z-pulse signals. 0 = DISABLE – Z-pulse input is not present or ignored if present. 1 = ENABLE – A Z-pulse input resets parameter 0146 MECH ANGLE to zero.	0, 1	1	0	✓

Group 50: Encoder					
Code	Description	Range	Resolution	Default	S
5011	POSITION RESET Resets the encoder's position feedback. This parameter is self-clearing. 0 = DISABLE – Inactive. 1 = ENABLE – Resets the encoder position feedback. Parameters reset depends on the state of parameter 5010 Z PLS ENABLE: • 5010 = ENABLE – Reset applies only to parameter 0147 MECH REVS. • 5010 = DISABLE – Reset applies to parameters 0147 MECH REVS and 0146 MECH ANGLE.	0, 1	1	0	

Diagnostics

Diagnostic LED

There is one diagnostic LED on the OTAC-01 module. If the OTAC-01 is properly installed, the green LED lights when the drive is powered up. If the LED does not light after power-up:

Step down this column. If an item is TRUE, look to the RIGHT for suggestions.	Corrective Action
The configuration may have failed.	Cycle the power supply of the drive.
The module connection may be damaged	 Warning! Dangerous voltages are present on the connector. Power down before attempting to repair connector pins. <ul style="list-style-type: none"> • Power down. • Remove the module and check the condition of the pins in the 6-pin connector. • Reconnect and retest.
The module may have failed.	Replace the module.

Fault/Warning

If the ACS550 detects that the encoder signal is lost, the drive operation and the diagnostic message are both controlled by parameter 5003 ENCODER FAULT:

- 5003 = 1 (FAULT) – The drive generates a fault (23 ENCODER ERR), and the motor coasts to a stop.
- 5003 = 2 (WARNING) – The drive generates an alarm (2024 ENCODER ERROR) and operates as is if parameter 5002 ENCODER ENABLE = 0 (DISABLE), that is, speed feedback is derived from the internal motor model.

In case of a fault or alarm signal, check for and correct:

Code	Name In Panel	Description and Recommended Corrective Action
23	ENCODER ERR	<p>The drive is not detecting a valid encoder signal. Check for and correct:</p> <ul style="list-style-type: none"> • Encoder presence and proper connection (reverse wired, loose connection, or short circuit). • Voltage logic levels are outside of the specified range. • Pulse Encoder Interface Module, OTAC-01, presence and proper connection to the ACS550.
2024	ENCODER ERROR	<ul style="list-style-type: none"> • Wrong value entered in parameter 5001 PULSE NR. A wrong value will only be detected if the error is such that the calculated slip is greater than 4 times the rated slip of the motor. • Encoder is not being used, but parameter 5002 ENCODER ENABLE = 1 (ENABLED)

Note: The validity of the encoder signal is also checked during the ID-run. See parameter 9910 MOTOR ID RUN. If the drive detects an encoder problem during the ID-run, the drive provides an alarm. Parameter 5003 FAULT ENABLE controls the drive's fault/alarm response to encoder errors only after the ID-run is completed.

Technical Data

Dimensions

Module dimensions are:

Ref.	mm	in
H	14.5	0.57
L	77.8	3.06
W	58.8	2.31

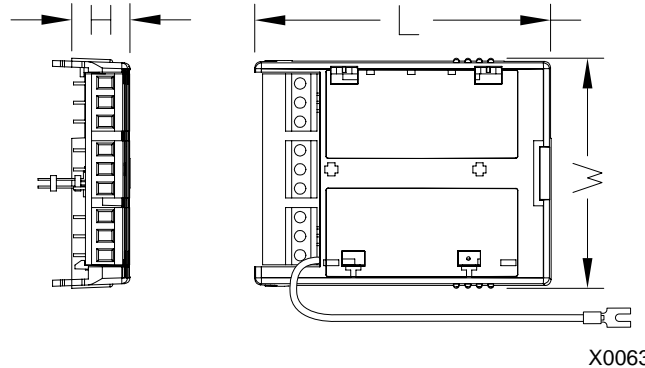

Enclosure Degree of Protection

The module is mounted inside the drive enclosure. Refer to the drive's rating.

Ambient Conditions

The module is mounted inside the drive enclosure. Refer to the drive's requirements.

Connectors

Connectors on the module:

- 6-pin connector
- Three, 3-pin, screw-type, non-detachable terminal blocks that accept wire connectors up to 1.5 mm² (16 AWG).
- Ground lead

Specifications

Module Specifications

The OTAC-01 module:

- Supports three channels: CH A, CH B, CH Z.
- Includes pass-through terminals to connect an external power supply (required) to the pulse encoder.
- All materials are UL-approved.

Channel Specifications

Channel specifications:

- Differential or single-ended
- Maximum input frequency: 200 kHz
- Input voltage range: 7.5 to 26 V (measured at the OTAC module)
- Nominal input impedance: 660 ohm (at 24 VDC)
- Isolated from logic and ground



3AJA000001938 REV C / EN
EFFECTIVE: JUNE 21, 2004
SUPERCEDES: APR. 15, 2004

ABB Oy
AC Drives
P.O. Box 184
FIN-00381 HELSINKI
FINLAND
Telephone +358 10 22 11
Telefax +358 10 22 22681
Internet <http://www.abb.com>

ABB Inc.
Drives and Power Electronics
16250 West Glendale Drive
New Berlin, WI 53151
USA
Telephone +1 262 785-3200
+1 800 243-4384
Telefax +1 262 780-5135